



PTFE THREAD SEAL TAPE

ZERO LEAKAGE - CLEAN & EFFECTIVE

"CHAMPION" PTFE Thread Sealant Tape, due to the special nature of the thread seal will be lasting and resistant to high temperatures and corrosive chemicals.

The seal will not harden or become brittle but will remain flexible enough when the seal is opened for maintenance.

"CHAMPION" PTFE Thread Sealant Tape can be used for various media from corrosive chemicals to water and gas to oil, in hydraulics and pneumatics.

Thread wrapping method

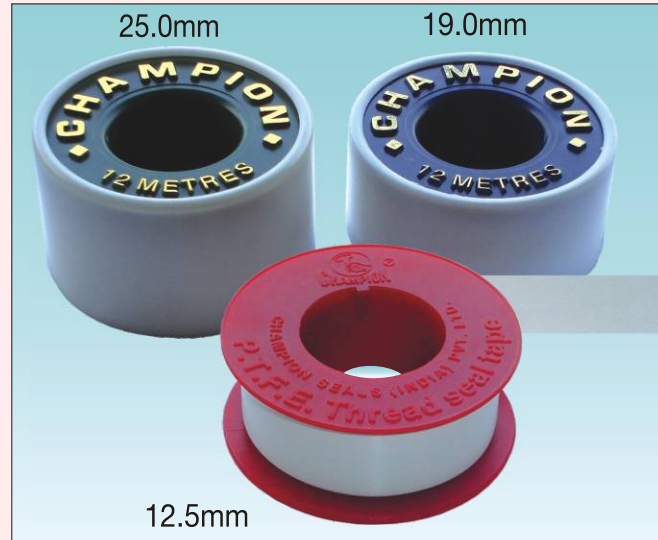
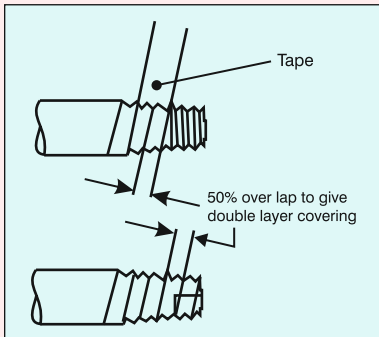

ALWAYS BUY GENUINE CHAMPION PRODUCTS

Instructions for proper usage:

Wind the tape by hand, using a constant minimal tension sufficient for the tape to take up the form of the thread. The tape should be wound in a helical fashion with a 50% overlap (as shown in the diagram) in the direction of the thread so that when the connection is completed the finishing end of the tape remains in position.

The tape width should not exceed the length of the thread form.

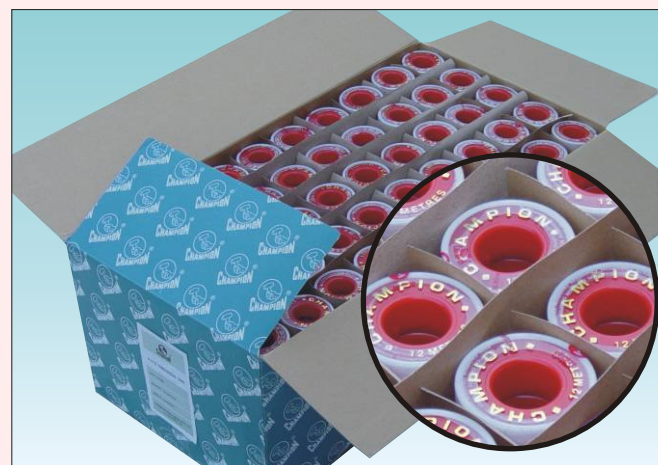

CHAMPION SEALS (INDIA) PVT. LTD.

Champion Compound, 15, Parsi Panchayat Road, Andheri (E), Mumbai - 400 069.
 Phone : +91-22-2836 7311-15 ■ Fax : +91-22-2836 7316 / 2820 8686
 E-mail: sales@championseals.in, impex@championseals.in ■ Web. www.championseals.in

Champion PTFE Flex-O-Seal Universal Joint Gasket

Product Description:

CHAMPION Flex-O-Seal is a unique sealing material manufactured from special grade of 100% expanded pure PTFE by transforming into a fibrous structure. Flex-O-Seal has a special peel off adhesive on one side. Though very tough, our Flex-O-Seal is soft and suited to all types of flanges, covers and narrow cavities. Due to its soft and flexible structure this rope gasket is an ideal seal under pressure, without significant cold flow even on irregular, badly damaged or corroded flange surfaces. Once bolted this gasket rarely needs to be re-torqued.

CHAMPION FLEX-O-SEAL is easy to install and is able to fill in severe surface irregularities. The flexible applications of this product allows reduction of inventory of ready made gaskets/envelopes, thereby the term UNIVERSAL JOINT GASKET

Physical Properties:

FLEX-O-SEAL can withstand a wide range of temperature as is recommended for use from -240°C to 310°C and pH Range 0 to 14. This product is resistant to high pressure and is **non-toxic as well as Asbestos FREE**, however it is not recommended for use against elemental fluorine, alkali metals and strong oxidizing agents.

Application:

FLEX-O-SEAL is safely used in applications on oil rigs, petroleum refineries, offshore operations, corrosive chemical processing, food processing, paper mill, marine installation, in glass lined or fibre glass reinforced vessels and tank lid sealing, heat exchangers, manhole covers, vent pipes, pumps or compressors housing flanges, valves and many other industrial applications where the use of a conventional pre-cut gaskets is not suitable or readily available.

Installation:

- At the time of installation, the sealing surface must be clean, free from grease and dry to enable the gasket to stick properly.
- The width of the joint gasket is to be determined by the nominal diameter or type of flange.
- Selection of a tentative size of joint gasket would be approx, 1/3rd flange contact width inside the bolt hole; example: 7 mm gasket joint to suit a 20mm flange width.
- Remove the protective foil from the adhesive joint gasket to allow for fitting.
- Stick the gasket about 2mm away from the bolt hole and press lightly.
- Do not butt the ends, instead overlap them in front of a bolt.
- Tighten the lubricated bolts in opposite pairs. The lap joint deforms perfectly to give a reliable seal.
- On irregular or damaged flanged surfaces, it is possible to build up with short length of FLEX-O-SEAL.



Standard Spools with Size :

Gasket Width mm	Thickness mm	Spool Length meter
3	1.5	30
5	2.0	20
7	2.5	15
10	3.0	8
14	5.0	5
14	3.0	5
17	3.0	5
17	6.0	5
20	3.0	5
20	7.0	5
25	10.0	5
20	5.0	5
25	5.0	5
25	7.0	5

PTFE Universal Rope

CHAMPION PTFE Universal Rope Gasket is soft un-sintered 100% pure expanded PTFE having a very smooth surface finish and is characterized by very low co-efficient of friction. This makes it a very useful sealing material and is used as a rope gasket on flanged connections of pipe, fittings, tanks & vessels and such other mating surfaces. as well as a gland packing in valve stem applications.

CHAMPION PTFE Universal Rope is a specially formulated sealing material that withstands vibration over a wide operating temperature range. The friction free characteristics promotes smoother action and increases the life of the gasket many times over.

Applications:

It is used as gasket on flanged connections, pressure vessels and all other similar mating faces as well as packing for valves and similar gland applications.

Dia: From 3.0mm to 19mm in round section.

Sizes Available: 3.0mmx30mtr., 4.0mmx10mtr., 5.0mmx10mtr., 6.0mmx10mtr., 8.0mmx10mtr., 10.0mmx5mtr., 12.5mmx5mtr., 16.0mmx5mtr., 19.0mmx5mtr.



Note: As the company's products are used for a multiplicity of purposes and as the company has no control over the method of their application or use, the company excludes all conditions or warranties, expressed or implied by statute or otherwise, as to their products and / of their fitness for any particular purpose. Any technical co-operation between the company and the customer is given for the customer's assistance only and without liability on the company.